

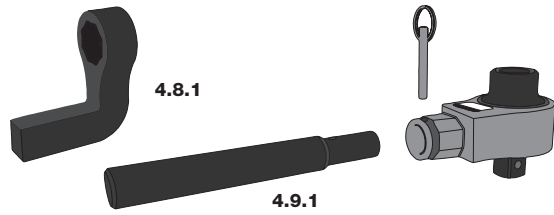

89049TM-1000



Reaction	Max N.m		Ratio	Input	Output
	Input	Output		In	In
	204	1000	4.9:1	1/2"	3/4"
	208	1000	4.8:1	1/2"	3/4"

8905-TM 9505-TM

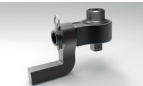

Reference	Max N.m		Ratio	Input	Output
	Input	Output		In	In
8905-TM	260	1300	5:1	1/2"	3/4"
9505-TM	540	2700	5:1	3/4"	1"

SNA Europe

TORQUE
MULTIPLIERS

BAHCO®

User's manual

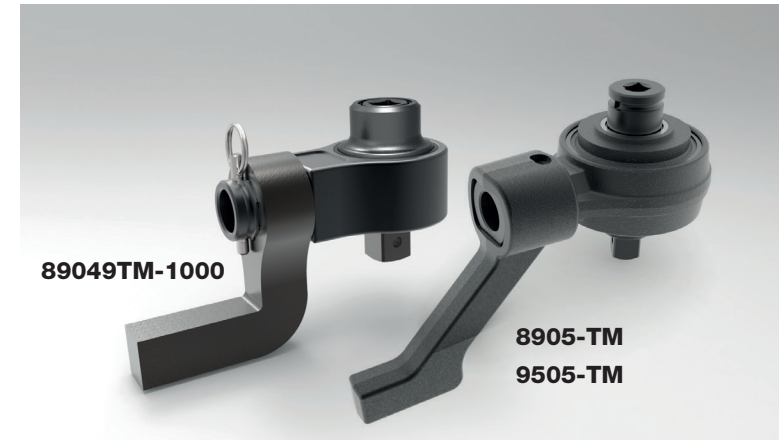

Follow the fish! www.bahco.com



SAFETY



IMPORTANT: DO NOT OPERATE THE TOOL BEFORE READING THESE INSTRUCTIONS. FAILURE TO DO SO MAY RESULT IN PERSONAL INJURY OR DAMAGE TO THE TOOL.

This tool is intended for use with threaded fasteners. Any other use is not recommended.

These tools require a reaction bar. See section on torque reaction.



There is a risk of crushing between the reaction bar and work piece.

Keep hands away from reaction bar.
Keep hands away from tool output.



WARNING: Risk of flying particles.

Over torquing can cause breakage. An out of calibration torque wrench can cause part or tool breakage. Broken hand tools, sockets or accessories can cause injury.



Wear safety goggles, user and bystanders.

Be sure all components, including all adaptors, extensions, drivers and sockets are rated to match or exceed the torque being applied.

Observe all equipment, system and manufacturer's warnings, cautions and procedures when using this tool.

Use the correct size socket for the fastener.

Do not use sockets showing wear or cracks.

Replace fasteners with rounded corners.



WARNING: Electrical Shock Hazard.

Electrical shock can cause injury. Tool is not insulated.

Do not use on live electrical circuits.

DRIVING TOOL



1. **For torque control and even bolt loading a torque wrench is required.**

2.A 89049TM-1000

Divide the required torque by either 4.9 (if using straight reaction) or 4.8 (if using cranked reaction) and then set your torque wrench to this figure. Do not exceed maximum input torque.

B 8905-TM 9505-TM

Set torque wrench to one fifth of the desired torque on the nut. Do not exceed maximum input torque.

3. Locate the multiplier onto the application ensuring the reaction bar is in a suitable position and insert your torque wrench.

IMPORTANT:

DO NOT USE THE MULTIPLIER WITH IMPACT OR IMPULSE WRENCHES.

REACTION



1. Select correct socket drive: it is recommended to use power drive sockets.
2. In use the tool body rotates in the opposite direction to applied drive. It is necessary to allow the torque reaction arm to rest against a solid stop before any useful work can be done.
3. To prevent undue stress on the gears always take torque reaction as far away from drive square as circumstances permit.

WARNING:

ALWAYS KEEP HANDS CLEAR OF THE REACTION BAR WHEN THE TOOL IS IN USE OR SERIOUS INJURY MAY RESULT.

NOTE:

Do not use the tool if the reactions, socket or tool appears damaged or close to failure.